

SECTION A-A
SCALE 1:1

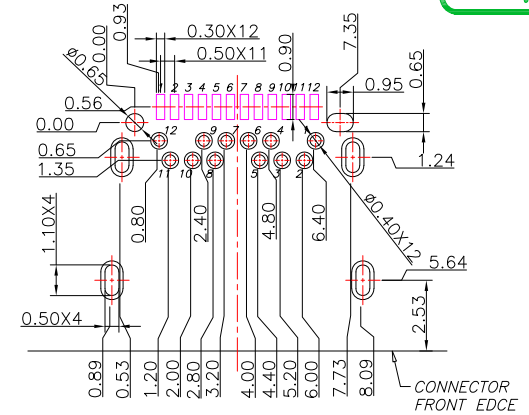

P.C.B LAYOUT

SPECIFICATIONS

Electrical:

- Rating: 5.0V, 5.0A
- Contact Resistance: 40 mΩ Max
- Insulation Resistance: 100 MΩ Min

Mechanical:

- Connector Mate and Unmate Force
 - Mate force: 5~20 N
 - Unmate force: 8~20 N

Material:

- Housing: LCP
- Contact: C18400
- Shell: SUS

Finish:

- Contact: Plated Gold in Mating Area ;
Tin Plated on Solder Balls ;
Nickel under plated overall
- Shell: Nickel under Plated surface layer

USB TYPE C PIN ASSIGNMENTS

PIN NUMBER	SIGNAL NAME	PIN NUMBER	SIGNAL NAME
A1	GND	B12	GND
A2	TX1+	B11	TX1+
A3	TX1-	B10	TX1-
A4	VBUS	B9	VBUS
A5	CC1	B8	SBU2
A6	DP1	B7	DN2
A7	DN1	B6	DP2
A8	SBU1	B5	CC2
A9	VBUS	B4	VBUS
A10	RX2-	B3	TX2-
A11	RX2+	B2	TX2+
A12	GND	B1	GND

CONTACT 建倚科技股份有限公司
CONTACT TECHNOLOGY CORP.

TOLERANCE UNLESS OTHERWISE STATED :
Up to 5 ±0.2
Above 5 ~ 15 ±0.3
Above 15 ~ 30 ±0.4
Above 30 ~ 50 ±0.5
Angle ±0.3

3RD. ANGEL'S

UNITS MM

DRAWN BY:	DATE	MAT'L	TITLE	CONNECTOR
Jack Lu	07/29/24	FINISH	MODLE	USB 3.1 TYPE C 母頭板上 SMT腳+PIN腳長1.20 Gen2X2 20Gbps
CHECKED BY:	DATE	SCALE	DWG NO.	SBC-240S46-33-S175
Jacky Chen	07/29/24	1 : 1	PART NO.	SBC-240S46-33-S175
APPROVED BY:	DATE	SHEET NO.	1 of 1	
Tony Kao	07/29/24			

ITEM NO.	DESCRIPTION	DRAWN	DATE
1	更新定位柱距離尺寸	Jack	072924